

# HTD-Zahnriemenscheiben

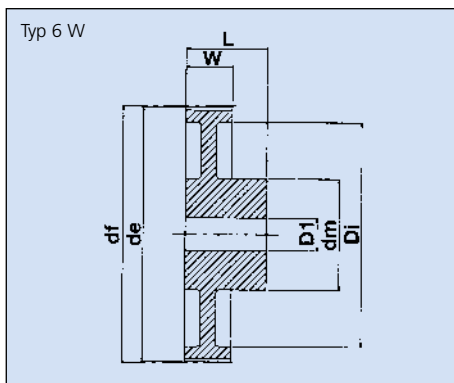
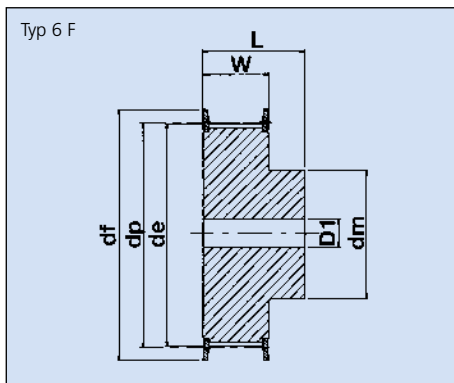
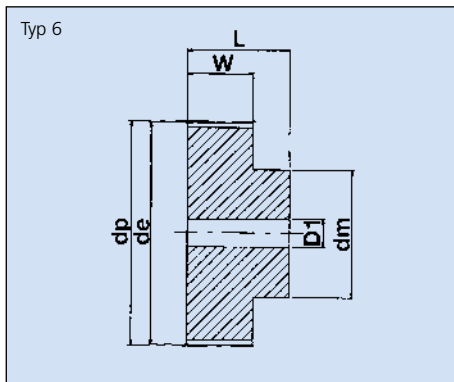
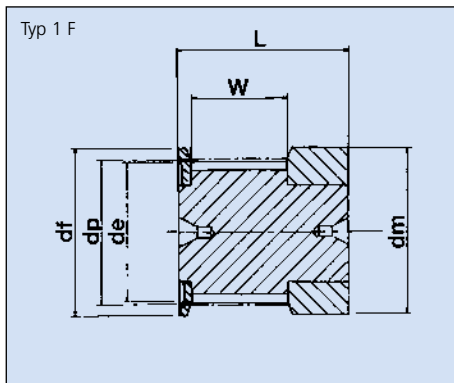

## 3M-09 (Teilung = 3 mm) – für Zahnriemenbreite = 9 mm

Artikel-Nr. Ketten Fuchs	Zähne- zahl	Typ	Werk- stoff	Abmessungen in mm								
				de	dp	dm	Di	df	W	L	D1	
10-3M-09	10	1F	Al	8,79	9,55	13,0	–	13,0	10,2	17,5	–	
12-3M-09	12	1F	Al	10,70	11,46	15,0	–	15,0	10,2	17,5	–	
14-3M-09	14	1F	Al	12,61	13,37	16,0	–	16,0	10,2	17,5	–	
15-3M-09	15	1F	Al	13,56	14,32	17,5	–	17,5	10,2	17,5	–	
16-3M-09	16	6F	Al	14,52	15,28	10,0	–	17,5	12,8	20,6	4,0	
18-3M-09	18	6F	Al	16,43	17,19	11,0	–	20,0	12,8	20,6	6,0	
20-3M-09	20	6F	Al	18,34	19,10	13,0	–	23,0	12,8	20,6	6,0	
21-3M-09	21	6F	Al	19,29	20,05	14,0	–	25,0	12,8	20,6	6,0	
22-3M-09	22	6F	Al	20,25	21,01	14,0	–	25,0	12,8	20,6	6,0	
24-3M-09	24	6F	Al	22,16	22,92	14,0	–	25,0	12,8	20,6	6,0	
26-3M-09	26	6F	Al	24,07	24,83	16,0	–	28,0	12,8	20,6	6,0	
28-3M-09	28	6F	Al	25,98	26,74	18,0	–	32,0	12,8	20,6	6,0	
30-3M-09	30	6F	Al	27,89	28,65	20,0	–	32,0	12,8	20,6	6,0	
32-3M-09	32	6F	Al	29,80	30,56	22,0	–	36,0	12,8	20,6	6,0	
36-3M-09	36	6F	Al	33,62	34,38	26,0	–	39,0	13,4	22,2	6,0	
40-3M-09	40	6F	Al	37,44	38,20	28,0	–	42,0	13,4	22,2	6,0	
44-3M-09	44	6	Al	41,26	42,02	33,0	–	48,0	13,4	22,2	6,0	
48-3M-09	48	6	Al	45,08	45,84	33,0	–	–	13,4	22,2	8,0	
60-3M-09	60	6	Al	56,54	57,30	33,0	–	–	13,4	22,2	8,0	
72-3M-09	72	6	Al	67,99	68,75	33,0	–	–	13,4	22,2	8,0	

## 3M-15 (Teilung = 3 mm) – für Zahnriemenbreite = 15 mm

Artikel-Nr. Ketten Fuchs	Zähne- zahl	Typ	Werk- stoff	Abmessungen in mm								
				de	dp	dm	Di	df	W	L	D1	
10-3M-15	10	1F	Al	8,79	9,55	13,0	–	13,0	17,0	26,0	–	
12-3M-15	12	1F	Al	10,70	11,46	15,0	–	15,0	17,0	26,0	–	
14-3M-15	14	1F	Al	12,61	13,37	16,0	–	16,0	17,0	26,0	–	
15-3M-15	15	1F	Al	13,56	14,32	17,5	–	17,5	17,0	26,0	–	
16-3M-15	16	6F	Al	14,52	15,28	10,0	–	17,5	19,5	26,0	4,0	
18-3M-15	18	6F	Al	16,43	17,19	11,0	–	20,0	19,5	26,0	6,0	
20-3M-15	20	6F	Al	18,34	19,10	13,0	–	23,0	19,5	26,0	6,0	
21-3M-15	21	6F	Al	19,29	20,05	14,0	–	25,0	19,5	26,0	6,0	
22-3M-15	22	6F	Al	20,25	21,01	14,0	–	25,0	19,5	26,0	6,0	
24-3M-15	24	6F	Al	22,16	22,92	14,0	–	25,0	19,5	26,0	6,0	
26-3M-15	26	6F	Al	24,07	24,83	16,0	–	28,0	19,5	26,0	6,0	
28-3M-15	28	6F	Al	25,98	26,74	18,0	–	32,0	19,5	26,0	6,0	
30-3M-15	30	6F	Al	27,89	28,65	20,0	–	32,0	19,5	26,0	6,0	
32-3M-15	32	6F	Al	29,80	30,56	22,0	–	36,0	19,5	26,0	6,0	
36-3M-15	36	6F	Al	33,62	34,38	26,0	–	39,0	20,0	30,0	6,0	
40-3M-15	40	6F	Al	37,44	38,20	28,0	–	42,0	20,0	30,0	6,0	
44-3M-15	44	6F	Al	41,26	42,02	33,0	–	48,0	20,0	30,0	6,0	
48-3M-15	48	6	Al	45,08	45,84	33,0	–	–	20,0	30,0	8,0	
60-3M-15	60	6	Al	56,54	57,30	33,0	–	–	20,0	30,0	8,0	
72-3M-15	72	6	Al	67,99	68,75	33,0	–	–	20,0	30,0	8,0	

## 5M-09 (Teilung = 5 mm) – für Zahnriemenbreite = 9 mm

Artikel-Nr. Ketten Fuchs	Zähne- zahl	Typ	Werk- stoff	Abmessungen in mm								
				de	dp	dm	Di	df	W	L	D1	
12-5M-09	12	6F	St	17,96	19,10	13,0	–	23,0	14,5	20,0	4,0	
14-5M-09	14	6F	St	21,14	22,28	13,0	–	25,0	14,5	20,0	6,0	
15-5M-09	15	6F	St	22,73	23,87	16,0	–	28,0	14,5	20,0	6,0	
16-5M-09	16	6F	St	24,32	25,46	16,5	–	28,0	14,5	20,0	6,0	
18-5M-09	18	6F	St	27,51	28,65	20,0	–	32,0	14,5	20,0	6,0	
20-5M-09	20	6F	St	30,69	31,82	23,0	–	36,0	14,5	22,5	6,0	
21-5M-09	21	6F	St	32,28	33,42	24,0	–	38,0	14,5	22,5	6,0	
22-5M-09	22	6F	St	33,87	35,01	25,5	–	39,0	14,5	22,5	6,0	
24-5M-09	24	6F	St	37,06	38,20	27,0	–	42,0	14,5	22,5	6,0	
26-5M-09	26	6F	St	40,24	41,38	30,0	–	44,0	14,5	22,5	6,0	
28-5M-09	28	6F	St	43,42	44,56	30,5	–	48,0	14,5	22,5	6,0	
30-5M-09	30	6F	St	46,60	47,75	35,0	–	51,0	14,5	22,5	6,0	
32-5M-09	32	6F	St	49,79	50,93	38,0	–	54,0	14,5	22,5	8,0	
36-5M-09	36	6F	St	56,16	57,30	38,0	–	60,0	14,5	22,5	8,0	
40-5M-09	40	6F	St	62,52	63,66	38,0	–	71,0	14,5	22,5	8,0	
44-5M-09	44	6W	Al	68,89	70,03	38,0	54,0	–	14,5	25,5	8,0	
48-5M-09	48	6W	Al	75,25	76,39	45,0	61,0	–	14,5	25,5	8,0	
60-5M-09	60	6W	Al	94,35	95,49	45,0	80,0	–	14,5	25,5	8,0	
72-5M-09	72	6W	Al	113,45	114,59	45,0	100,0	–	14,5	25,5	8,0	

### Bestellbeispiel

48	5M	25
	Zähnezahl 48	
	Riementeilung 5 mm	
	Riemenbreite 25 mm	

### lieferbar:

– mit Vorbohrung oder Fertigbohrung mit Nut nach DIN-Nr. 6885